



Dash Cam Install Guide



KONEXIAL

What's Included?

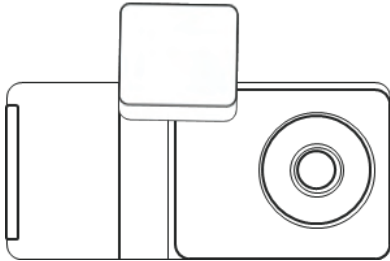

LogiCam Camera

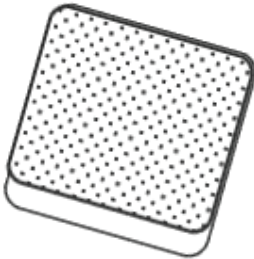

Mounting Bracket

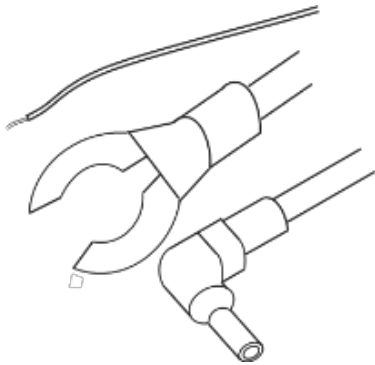

Hardware Kit



Proprietary Screwdriver

Road-Facing Camera

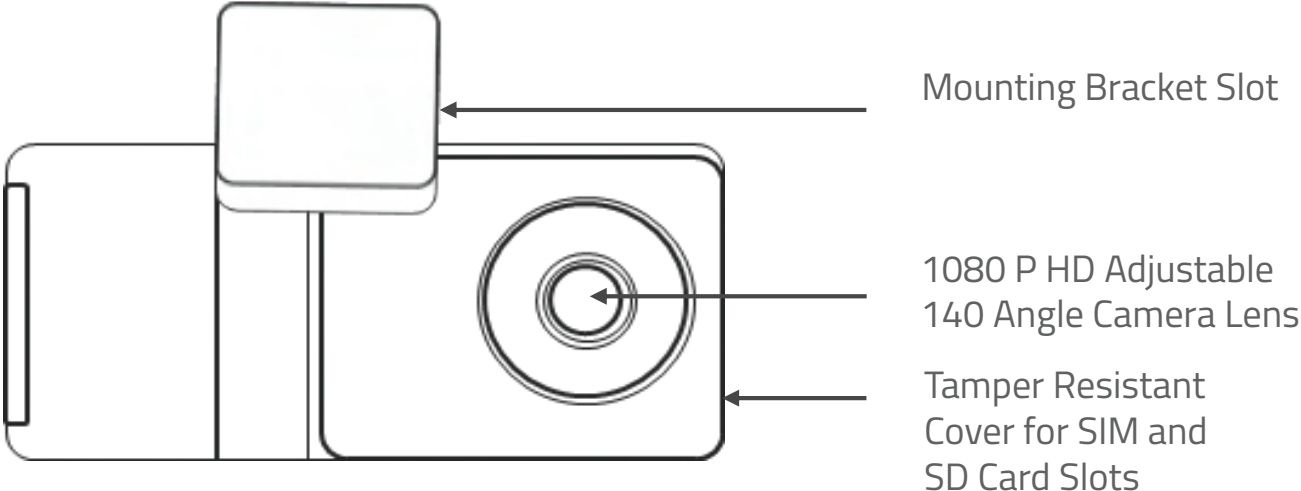

Driver-Facing Camera

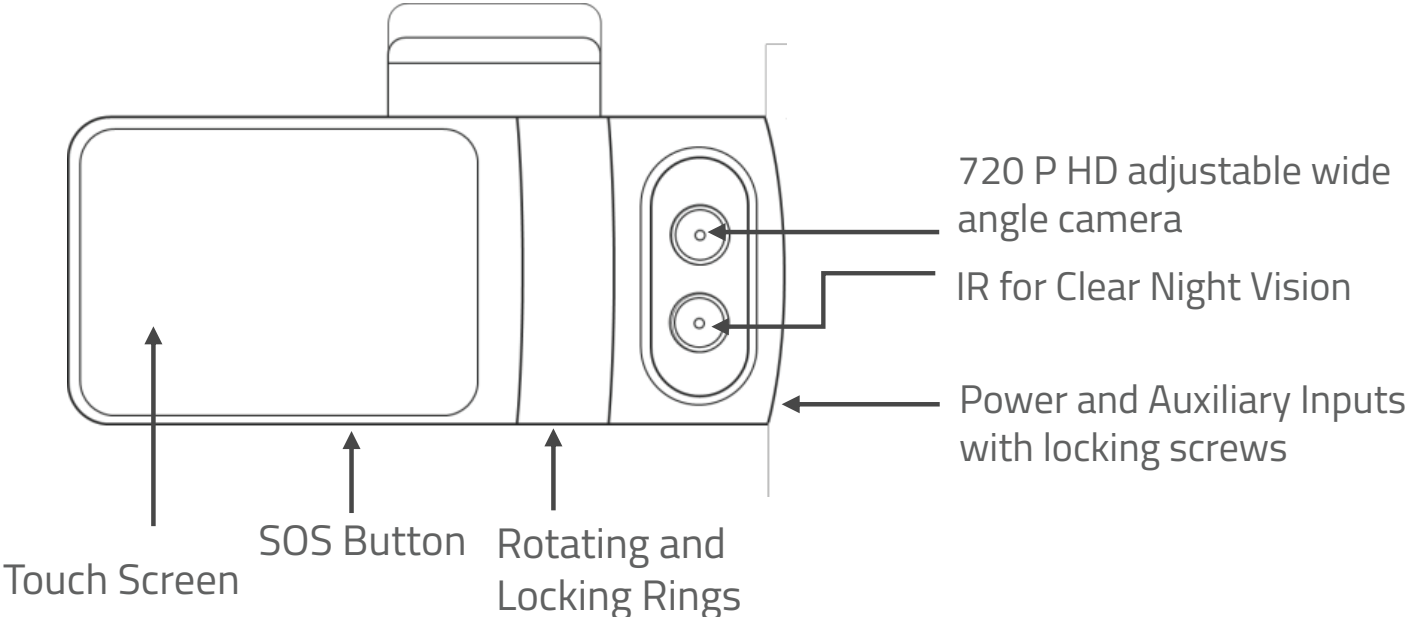

Install My20 LogiCam

Before you start the install, make sure that the vehicle is parked on a level surface and that the windshield is clean and dry.

- Unscrew the safety screw that lock the tamper proof cause using the specialty screwdriver.
- Insert the SIM and SD cards.
- Attach the mounting bracket onto the camera.
- Place the camera as high as possible on the driver side of the vehicle.
- Remove the 3M adhesive tape cover, and mount the camera to the windshield.

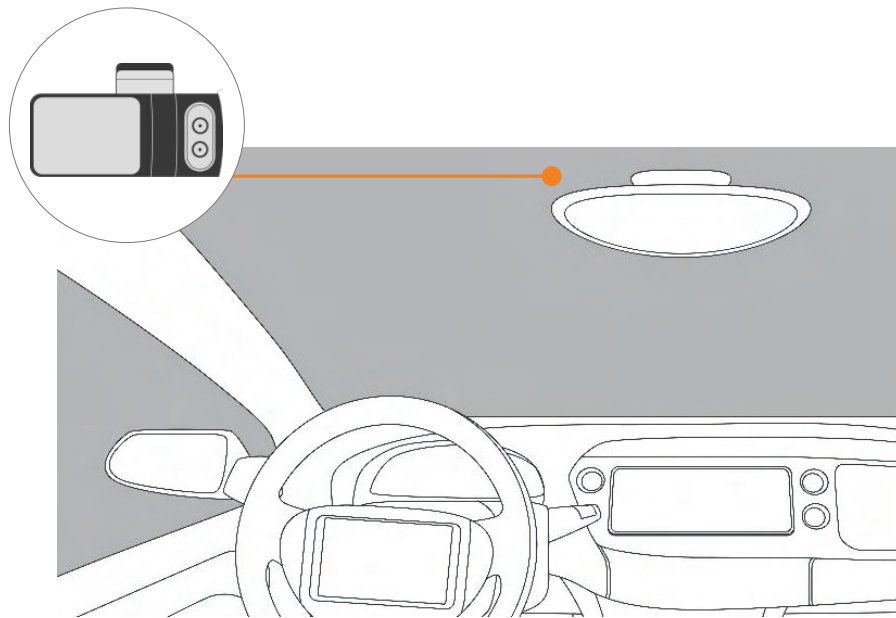

 DO NOT INSTALL THE PRODUCT IN A LOCATION WHERE IT CAN OBSTRUCT THE DRIVERS FIELD OF VISION.

Adjusting the Angles

- Dismount the LogiCam camera from the mounting bracket on the windshield. Make sure that the mounting bracket is not attached, as it locks the camera into position.
- Use the screwdriver to loosen the three security screws on the round side of the camera. Do not remove the screws fully.
- Adjust the viewing angle by rotating the body of the LogiCam and lock the three side screws when finished.

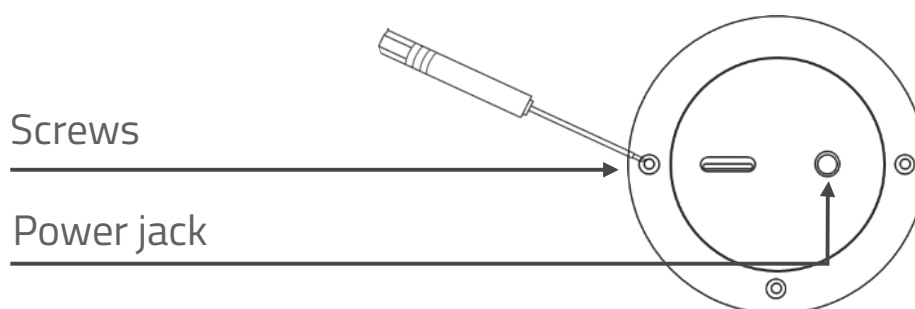

- Mount the camera back onto the windshield.
- Connect the camera to a power source (page 7).
- The camera will turn on automatically.
- To unblock the camera touch screen enter a default PIN number 3333.

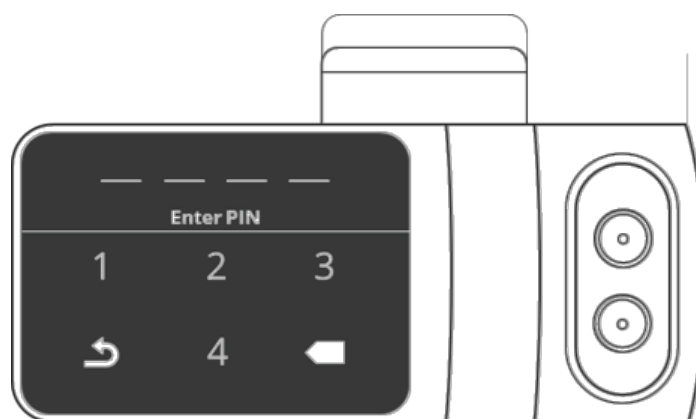

Adjusting the Angles

- On the main screen enter the “Live View” mode.
- Use the “Live View” to direct the road facing camera and the cabin facing camera to the proper direction. You can use the arrow keys to switch between the views.
- Dismount the camera from the windshield and screw in the security screws all the way. Mount the camera back on the windshield.

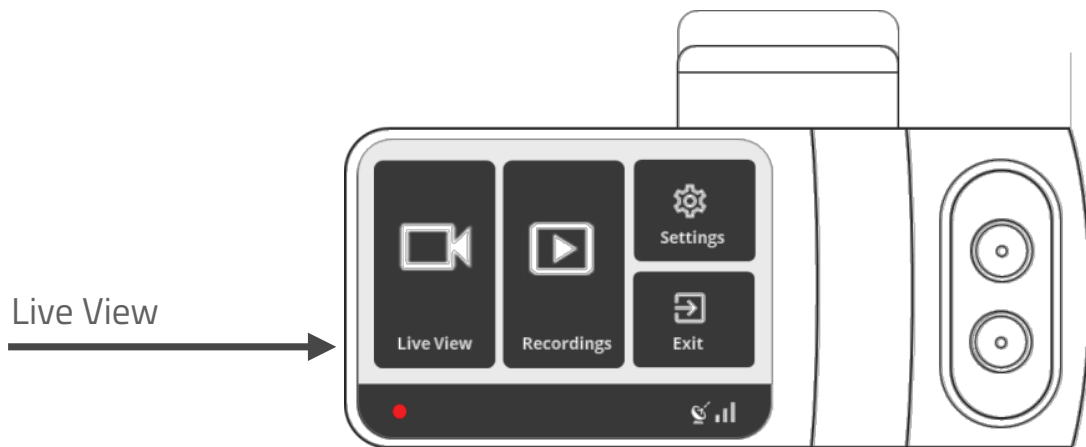
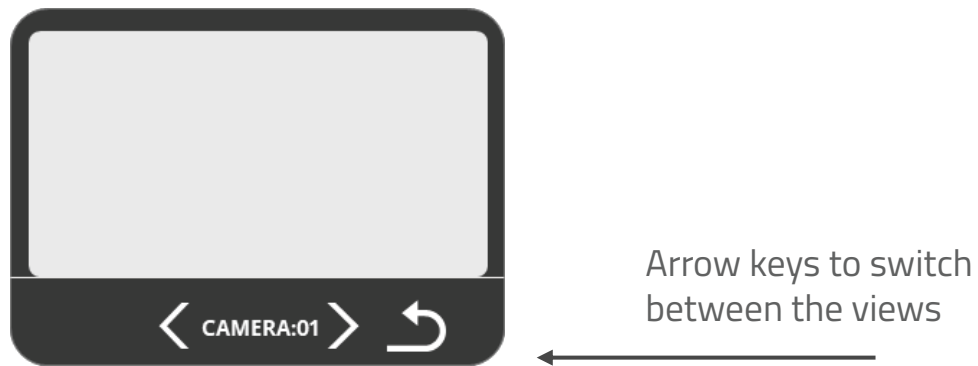

Connect to a Power Source

- The LogiCam may only be connected to a power source using the supplied cables.
- The camera's cylinder side is where the input power connector is located.
- In order to utilize the LogiCam full features such as active standby, the camera must be connected to a constant 12v power source.



Access the Settings Menu

- Press the camera touchscreen.
- Enter the default PIN number 3333.
- The camera is now unlocked and the Settings menu is now accessible.

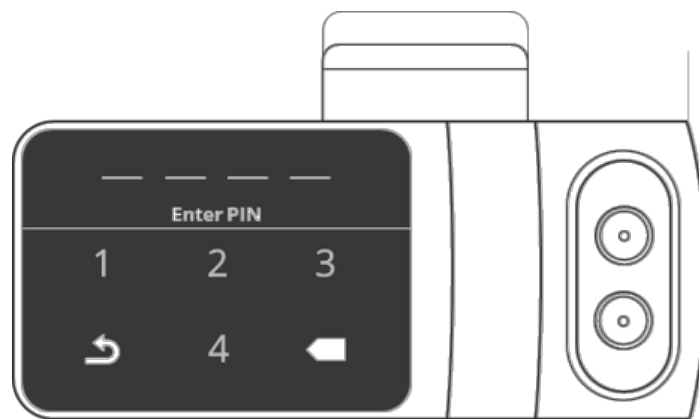

Calibrating the LogiCam Sensors

The LogiCam contains an internal accelerometer that detects unsafe driving events. The accelerometer is not calibrated in advance as the installation in every vehicle is different. Please follow the following steps to calibrate the accelerometer. Before you start, make sure that the vehicle is parked on a level surface.

- Turn off the vehicle's ignition.
- Check that the camera is on.
- Press the touchscreen and enter the security PIN.
- Enter into the "Settings" menu.
- Select "Calibrate".

*The calibration process takes about a second once completed.

Note: Recalibration is required in case of transferring the dash cam to another vehicle.

Settings Menu

Enter the "Settings" mode in the main menu to set your camera:

- WiFi Hotspot
- Video Preset
- Select APN
- Driver Camera
- Text Overlay
- Distracted Driver
- In-Cabin Recording
- Driver Position
- U.S. Date Format
- Speed in MPH
- Audio Alarms
- Notify Live Streaming
- Change PIN
- Change Driver PIN
- Calibration
- Brightness
- Serial Numbers
- Format SD Card
- Power Off

View Live Video

- Enter the “Live View” mode in the main menu.
- The live video will be displayed on the screen.
- Use the arrow keys below the screen to switch between the road and cabin facing cameras.
- Use the arrow back button to return to the main menu.

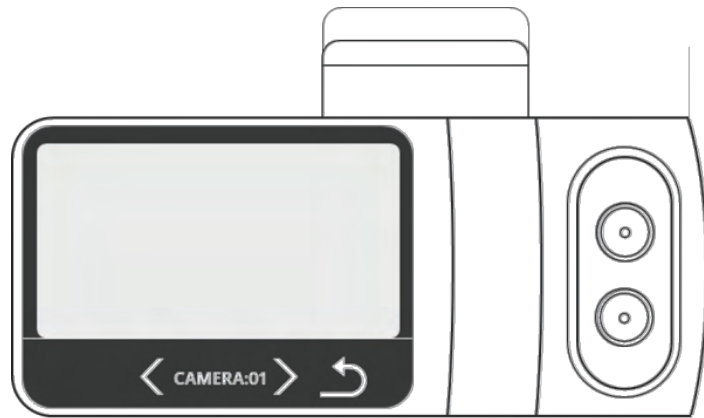
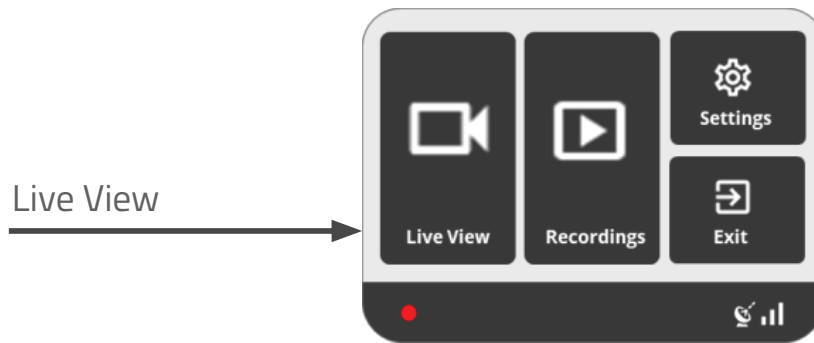

Arrow keys switch between the views

Back

View Recorded Videos

- Enter the “Recordings” mode in the main menu.
- All the recorded videos on the SD card will be displayed in a list, sorted by date and time.
- Use the arrow buttons to scroll through the list.
- Select the video you would like to view and then click the “Play” button.

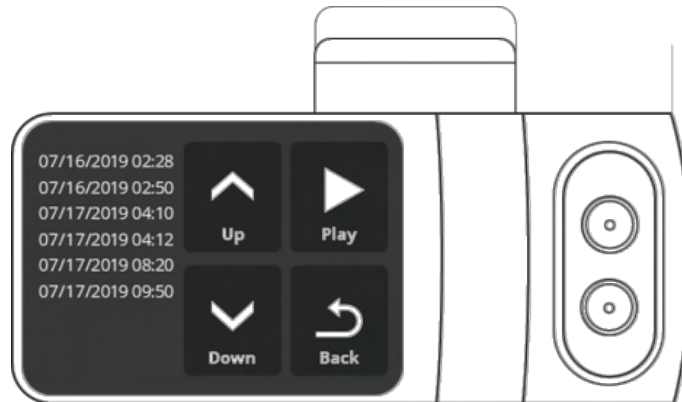

Driving Alerts

- A white vehicle icon will be displayed on the screen while driving.
- In case of a dangerous driving event such as violent turn or unsafe driver behavior, the car icon will turn red, indicating a visual alert for the driver.
- In addition, a noise alert will sound off from the camera.

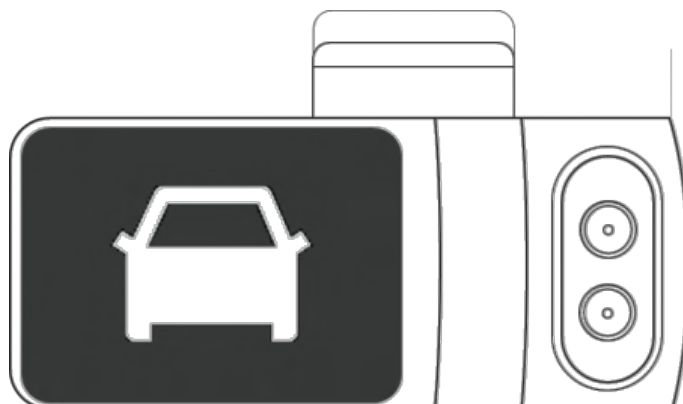

Hardwire Your Camera

Hardwiring a dash cam is one of the most common installation methods to power on your dash cam. In order to utilize the LogiCam full features such as active standby, the camera must be connected to a constant 12v power source.

NOTE: The hardwiring kit includes 2 wires; one **RED** wire that connects to a constant 12v sources and a **BLACK** ground wire that will go to a metal ground bolt.

Essential Install Package

WARNING: This type of installation should be performed by a qualified or professional person only. Working with you vehicle's power system can be dangerous for you and your vehicle. In any doubt, consult a professional.

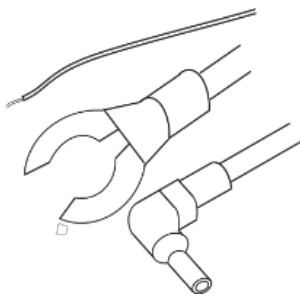

Hardwire Kit

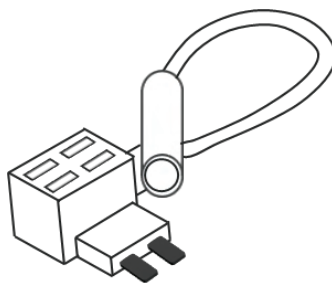

Add a Fuse Kit



Fuse Tape

Step 1: Locate Your Fuse Box

Check the car owner's manual for the fuse box location. It may vary depending on the vehicle model. Remove the plastic panel to access the fuse box. It may open simply by lifting a tab or pulling it with your fingers, or use a flat tool that can pinch in between the plastics.

Step 2: Which Slot Should I Use?

Use a circuit tester to test which fuse is constant (typically red) and provides 12v of power. A fuse that is constant will stay active when the car is off. The camera will automatically enter standby mode when the car is not moving for 10 minutes.

Step 3: Add-a-Fuse Kit

We recommend using an add-a-fuse kit included in our Essential Install Package, for a more secure, long lasting installation. The add-a-fuse kit provides a fuse slot for the existing OEN circuit (12v constant, #2 in picture below) and another fuse slot for the new circuit for the dash cam device (#1 in picture below).

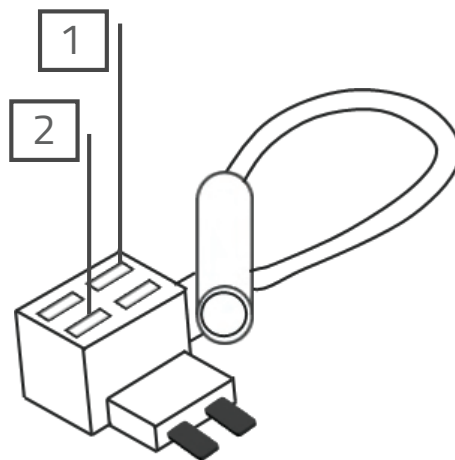

Hardwire to the Vehicle Fusebox

1. Insert the new fuse tap provided in the kit into "slot 1", and the fuse from the fuse box into "slot 2" (12v constant or ignition switch). If you set them with the wrong order, it will not feed power to the hardware kit.

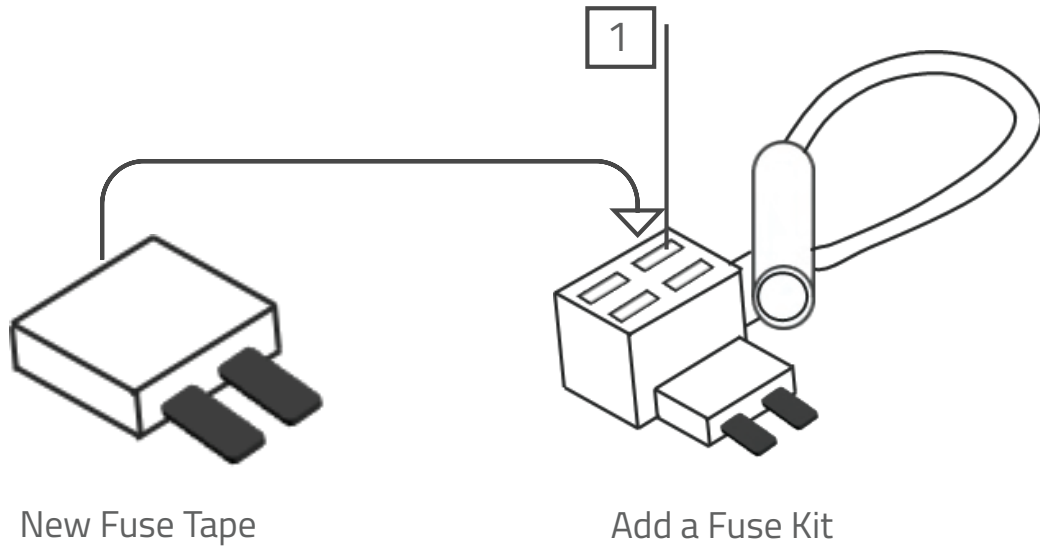

2. Connect the hardwiring cable with the terminal crimp connector from the add-a-fuse kit. Trim off some of the rubber tubing to expose the wiring on your hardwiring cable. Then crimp them down together. You should be able to crimp the fuse kit with a standard needle nose pliers. We recommend using electrical tape to further secure the wire.

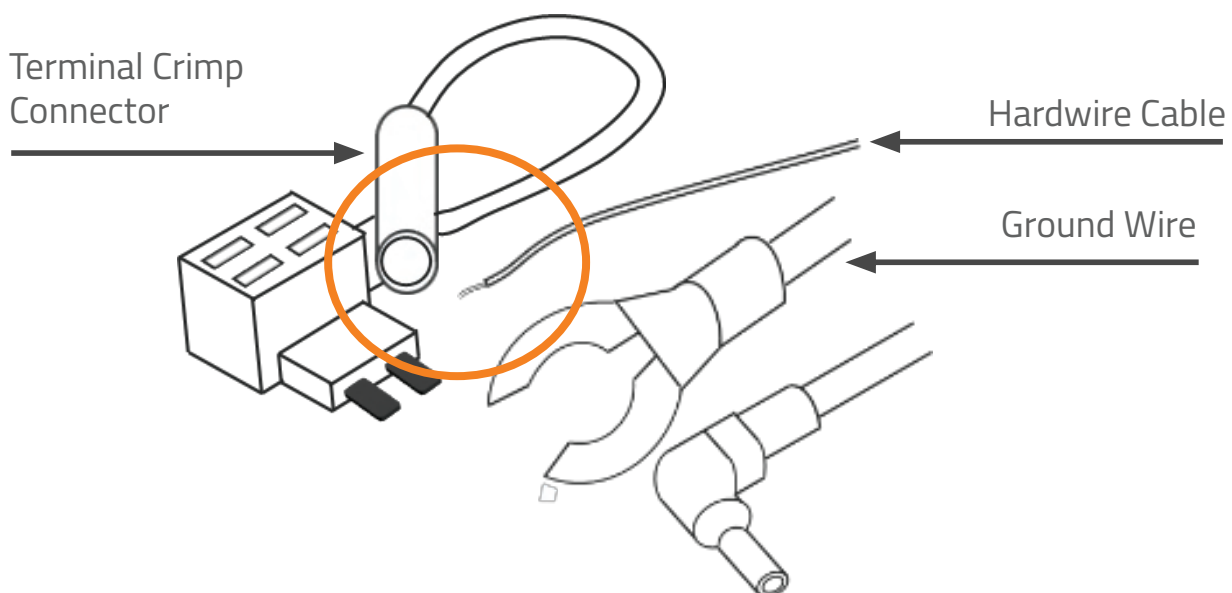

3. Connect you add-a-fuse kit to the vehicle fuse slot that you have chosen.

Step 4: Ground the Hardwire Kit

4. The ground wire is usually in a C shape or a ring. To connect the ground wire, slip it under a metal bolt or screw in your vehicle.
5. You may need a socket wrench set to loosen the bolt. Loosen the bolt enough to slip it in and tighten it back up afterwards. A loose ground can result in power issues for your dash cam. We recommend grounding your wire to an unpainted bare metal bolt.

Step 5: Test Your Dash Cam

Plug the power cable to the dash cam. Start your vehicle to test if the dash cam powers up. Once you tested your dash cam, run the power cable along the headliner of the car along the A-Pillar to the power source for a clean installation.

That's it. You've successfully installed your dash cam!

**For additional assistance please contact
support@konexial.com
865-888-MY20**